

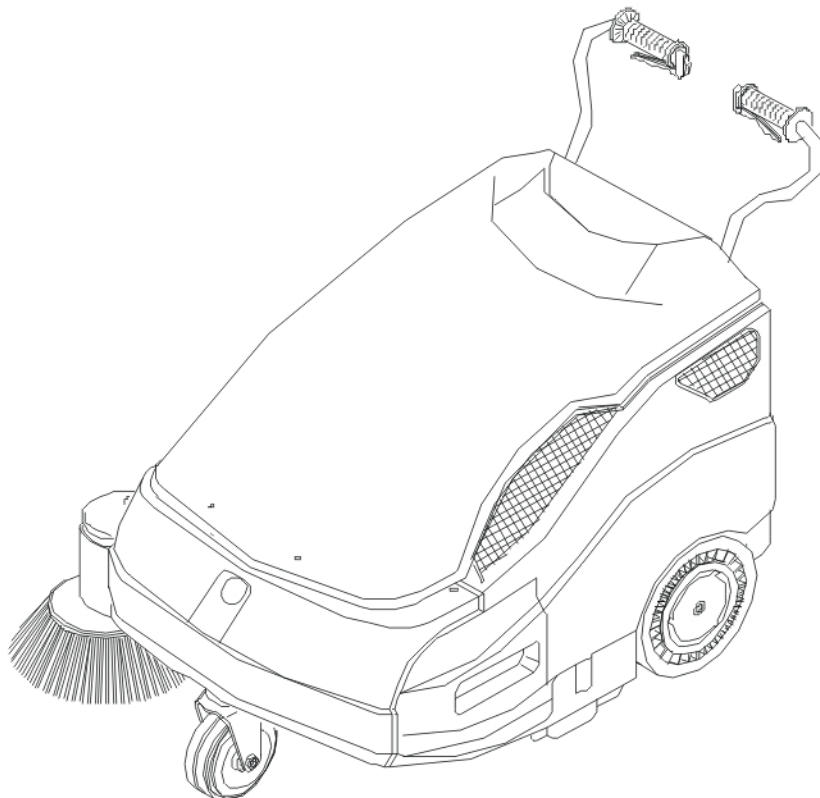

**OPERATOR'S MANUAL
BEDIENUNGSANLEITUNG
MANUEL D'INSTRUCTIONS
MANUAL DE INSTRUCCIONES
MANUALE D'USO**



SILVER 510 / 710

AUTOMATIC SWEEPER

SPAZZATRICE ELETTRICA

GENERAL INFORMATION - KEY

Any **RIGHT** or **LEFT-CLOCKWISE** or **COUNTER CLOCKWISE** indications included in this handbook are always to be intended with respect to the machine's direction of movement.

NOTE

This symbol draws your attention to operations that could cause **damage to the machine** if improperly executed.



This symbol draws your attention to operations that could cause **injury to the operator** if improperly executed.



This symbol draws your attention to operations that must be read about **very carefully**.

Consult this manual carefully to gain confidence with your machine and learn how to use it more efficiently.

1.1 - SECURITY WARNING



All the paragraph in the following chapter may cause damage to people and/or object if improperly executed.

ALWAYS KEEP THE MACHINE OUT OF THE CHILDREN'S REACH.

IMPORTANT NOTE

Precautions to be taken before attempting to start the machine:

To facilitate transport, the side brush, the handlebar and the upper casing have not been assembled in their actual work position. Therefore before using the machine, assemble them as shown in this handbook.

Do not use the machine to soak up liquid.

The machine must be used by authorised personnel only.

Before cleaning or servicing the machine, always turn it off.

As the machine is not provided with a parking brake or service brake, pay attention when you are using it on sloping surfaces.

Do not leave the machine unattended on sloping surfaces.

The machine must be used only by qualified and authorised personnel.

For this purpose, **NEVER:**

- use the machine to transport people;
- touch the moving parts of the machine;
- remove the machine's guards when it is running;
- do not leave the operating machine unattended.

The petrol-powered machine must be used in open and aired places only.

Always wear clothing suiting the kind of work you are carrying out. If you are working in a particularly dusty environment (for instance, cement factories, sawmills, marble processing factories), it is recommended to wear:

- a mask;
- protective goggles;
- gloves.

Do not use a jet of water in order to wash the machine.

The machine must not be used for the sucking of the toxic substances.

The machine can only work in presence of light.

NEVER LEAVE the machine with the key in the dashboard unattended.

In case the machine is being used in a place where there's a danger for falling little objects, an helmet must be worn by the operator.

Do not use the machine to sweep up cables, straps, wire, or similar material.

Do not use the machine near cables, wire, or similar material.

Illegible text block.

IMPORTANT: the manufacturer cannot be held responsible for damage in the event that the machine is used for purposes other than those it was designed for. The machine **must never be** tempered with for any reason whatsoever; in this event, the manufacturer will accept no responsibility for improper use or damage to the machine.

1.2 - SERIAL NUMBER AND CE MARKING

Always ensure that the machine is provided with a name plate giving the **serial number** and **CE marking** in the position shown in **Fig. 1**. On the contrary advise your dealer immediately.

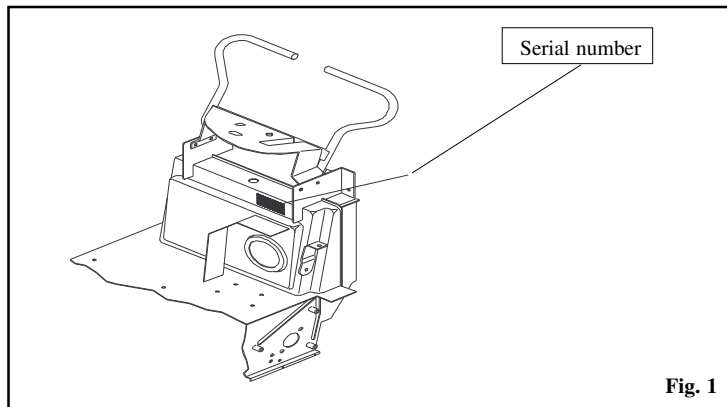

1.3 - FOREWORD

The purpose of this manual is to inform the operator of the basic rules, safety rules and criteria which must be observed when using, adjusting and maintaining the machine. The machine has been developed and has been developed and manufactured to ensure an excellent performance and the utmost comfort and ease of operation in a variety of working conditions. Before delivery, the machine has been checked at our factory and by our dealer to make sure it is handed over to you in perfect working order. To maintain the machine in this condition and ensure problem free operation, it is essential to follow the routine maintenance instructions given in this handbook.

1.4 - UTILIZATION FIELD

The machine, composed of a brush and a suction system, is to be used **EXCLUSIVELY** to clean dry surfaces. Any other use could be cause of damage to people or things and is therefore **PROHIBITED**.

1.5 - UNPACKING THE MACHINE

Unpack the machine with the utmost care; avoid carrying out any operation that could damage it. Once it has been unpacked, check whether it is damaged. If you notice that it is not in correct working order, **DO NOT** use it and inform your dealer.

For packaging and transport purposes, some parts and accessories are supplied disconnected from the machine. To assemble them, carefully follow the instructions given in the relevant sections.

Contents of package:

- N° 1 Machine.
- N° 1 Side brush.
- N° 1 Instructions and spareparts manual.
- N° 2 Ignition keys.
- N° 1 Declaration of conformity.
- N° 1 Warranty slip.

In the case in which one of the above mentioned parts is missing, place inform your dealer straight away.



Take care to keep the packaging materials (bags, cartons, pallets, hooks, etc) **out of the reach of children**.

NOTE

For security reason during the transport, the ignition keys as been fixed to the handle.

1.6 - CONSOMABLES

Gear motor: MOVIBLAK 300 lithium grease with similar features.

Battery: Distilled water.

Engine: UNLEADED petrol. Motor oil.

2.1 - PREPARING THE MACHINE FOR OPERATION (Version with motor - Version with engine)

2.1.1 - Mounting the side brush (Version with motor - Version with engine)

- Switch the brush lift lever **pos. 1 Fig. 3**, to **OFF**.
- Remove the screw from the side brush drive shaft.
- Fit the brush on the shaft.
- Screw on the screw and washer.

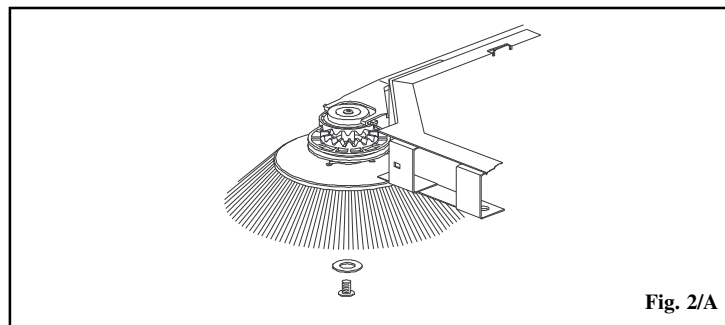

2.1.2 - Mounting the handlebar (Version with motor - Version with engine)

- Loosen the handlebar fixing screws.
- Position the handlebar in work position.
- Tighten the handlebar fixing screws.

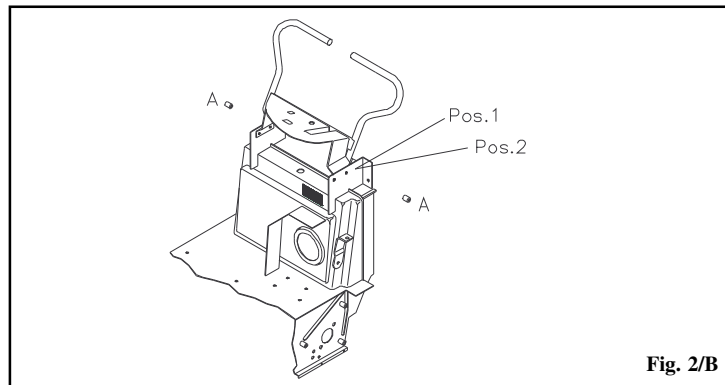

2.1.3 - Mounting the bonnet (Version with motor - Version with engine)

Prepare the battery or the gas motor before proceeding to the assembling of the cover. Once you have done this:

- Loosen the bonnet fixing handwheels.
- Position the bonnet on the machine.
- Tighten the handwheels.

2.2 - PREPARING THE BATTERY



The battery must be prepared before it is mounted on the machine. This simple precaution will prevent the machine from being damaged by the electrolytic liquid of the battery.

NOTE

Always prepare the battery in a sufficient ventilated environment. Do not smoke or use naked flames during this operation (see the section on battery maintenance). Once the battery has been charged, make sure the electrolytic liquid containers are stored in a safe place **AWAY FROM CHILDREN**.

2.3 - PREPARING THE ENGINE FOR OPERATION



Check the level of the oil in the engine. Fill the fuel tank with **UNLEADED PETROL**. Make sure switch **pos. 9 Fig. 5** located on the engine, is turned to **OFF**, otherwise

NOTE

you will not be able to operate the key **pos. 2 Fig. 3** on the dashboard. For more detailed information on the engine consult the relevant manual.

3.1 - CONTROLS

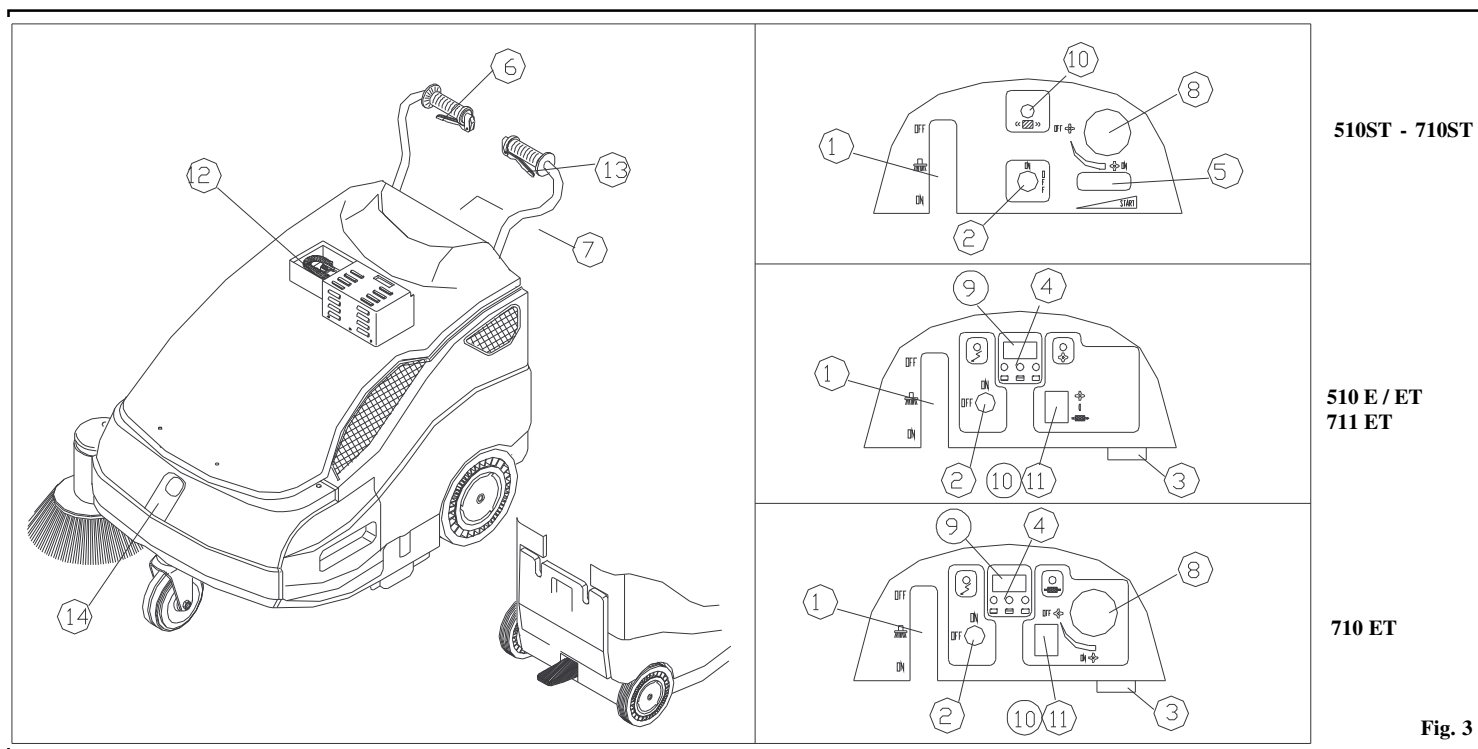

Fig. 3

- 1) **Side brush control lever:** switch the lever to **ON** and the side brush will move to work position and start spinning. To stop the brush, switch the lever to **OFF**.
- 2) **Key switch:** this switch starts and stops all the machine's functions.
- 3) **Battery charger socket** (on the electric version only): by plugging a **12 V 10A** battery charger in this socket you will recharge the battery (see the section on battery recharging).
- 4) **Charge indicator light** (on the electric version only): this light indicates the state of the battery during operation.
- 5) **Accelerator lever** (on the engine version only): operate this lever to regulate the speed of the machine.
- 6) **Traction lever:** by pressing this lever, the machine will start moving forwards.
- 7) **Filter shaker lever:** this lever operates the filter shaker to clean the filter (see the section on filter maintenance).
- 8) **Knob to operate the air suction inlet** (located under the cover): this opens or closes the suction valve.
- 9) **Timer** (on the electric version only): it points out the total amount of the work hours of the machine (Optional).
- 10) **Filtershacker button** (Optional).
- 11) **Suction switch.**
- 12) **Battery charger on board version** (Optional)
- 13) **Flap raise lever**
- 14) **Front hopper unblocking lever**

4.1 - STARTING

ATTENTION: the machine must be used by authorised personnel only. **DO NOT** leave the machine **UNATTENDED** when it is running. Do not use the machine to soak up liquid. Take out the key before leaving the machine. **KEEP THE MACHINE OUT OF CHILDREN'S REACH.**

4.1.1 - Electrical version

To start the machine carry out the following operations:

- Make sure the side brush **pos. 1 Fig. 3** is **OFF**.
 - Turn the switch **pos. 2 Fig. 3 ON**. Wait 10 seconds before the machine sets off.
 - Before the machine sets working, check the indicator **pos. 4 Fig. 3**, to assess whether the battery is fully charged. If it is not, proceed to recharge it.
 - Pull the traction lever **pos. 6 Fig. 3**, to start cleaning.
- If necessary, operate lever **pos. 1 Fig. 3**, by turning it **ON**, to start the side brush. If you have been using the side brush, at the end of your work remember to turn it **OFF**. Switch off the machine and remove the key from the control panel.

NOTE An automatic device will prevent you from using the machine beyond a certain battery charge limit.

When this limit is reached, the machine will stop and the battery **must be recharged**.

4.1.2 - Engine version

- Make sure the side brush **pos. 1 Fig. 3**, is **OFF**.
- Ensure that engine has enough petrol and oil.
- Switch accelerator lever **pos. 5 Fig. 3**, to **START**.
- Place the key **pos. 2 Fig. 3** on **ON** position.
- Open up fuel tap **pos. 3 Fig. 4**.
- If the engine is cold, operate the choke lever **pos. 2 Fig. 4**.
- Operate the start handle **pos. 7 Fig. 4**.
- As soon as the engine starts running, shut off the choke lever **pos. 2 Fig. 4** if it was operated.
- Act on the accelerator **pos. 5 Fig. 3**, to reach the required speed.
- At the end of your work, if you have been using the side brush **pos. 1 Fig. 3** turn it **OFF**. Turn the accelerator lever to **START** and turn off the machine with the key **pos. 2 Fig. 3**. Close up fuel tap **pos. 3 Fig. 4**.

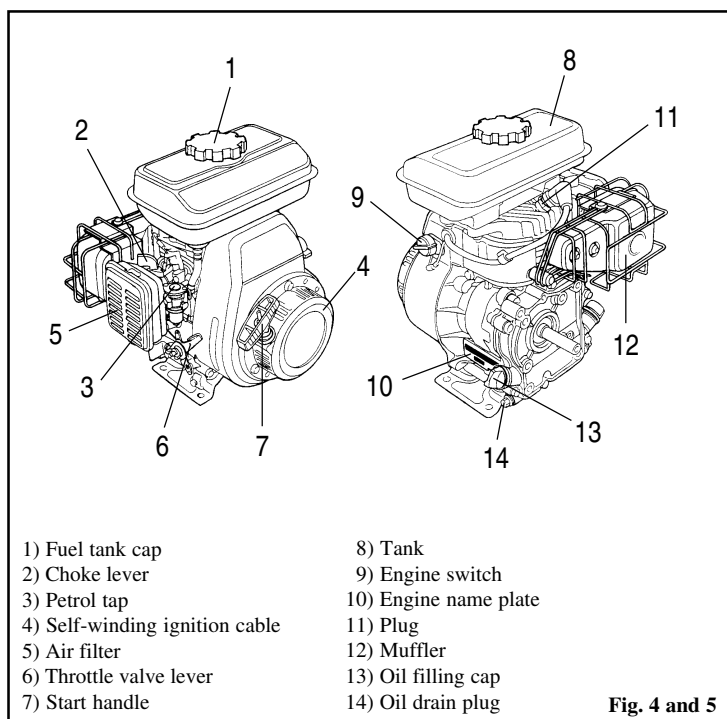

4.2 - CORRECT OPERATION

After you have become conversant with the operations required to start the machine, you can actually start using the sweeper to obtain the best results, it is always wise to take a few precautions. These will help you to get the best from your machine and reduce damage to a minimum. In particular:

- do not use the machine to clean up wires, ropes or straps or soak up water and other liquids.
- When using the machine on light but bulky material (sheets of paper, leaves, etc.), raise the front part of the machine by pressing down the handlebar so that the machine can tackle the rubbish.
- Operate the filter shaker at the end of your work (see the Panel filter section).
- Make sure the centre brush is correctly regulated (see the section on Adjusting the centre brush).



NOTE

DANGER: petrol is highly inflammable. Keep your fuel in containers designated for the purpose. Top up your fuel tank **ONLY** when the engine is off. Do not remove the fuel tank cap when the motor is running or hot. Always fill your fuel tank in open air or in a sufficiently ventilated area. Do not smoke during this operation and do not use naked flames. If you spill fuel during this operation, **DO NOT** attempt to start the engine but wait for the vapour to evaporate.

Always turn off the engine:

- Before leaving the machine unattended;
- Before filling the fuel tank;
- Before carrying out any work on the machine.

4.3 - CLEANING THE WASTE BINS

Before carrying out this operation, make sure all parts are off.

(*) **ATTENTION: WASTES MUST BE DISPOSED OF STRICTLY IN ACCORDANCE TO THE LAW.**

4.3.1 - Front bin

- Lift and turn the two bin locks.
- Grasp the handle/s and remove the bin by pulling it upwards.
- Empty the bin (*).

To put the bin back in place:

- Put the bin back in the machine from the top.
- Turn and lower the two locks.

4.3.2 - Rear bin

- Lift and turn the two bin locks.
- Grasp the handle and pull the bin out of the machine.
- Empty the bin (*).

To put the bin back in place:

- Fit the bin back into the machine.
- Turn and press the two locks.

NOTE

5.1 - ROUTINE MAINTENANCE

ALL ROUTINE MAINTENANCE AND SPECIAL MAINTENANCE MUST BE CARRIED OUT BY COMPETENT PERSONNEL OR BY ANAUTHORISED SERVICE CENTRE. ALWAYS USE ORIGINAL SPARE PARTS. ATTENTION ALL MAINTENANCE OPERATIONS MUST BE CARRIED OUT WITH THE MACHINE OFF.

CHECK	On delivery	Every 10 hours	Every 50 hours	Every 100 hours
Check the battery liquid	X	X		
The belts for slackening				X
The tightness of nuts and screws			X	
The brushes for wear			X	
The gaskets for wear and leakages		X		
If all the functions are in working order	X			X

5.2 - BATTERY MAINTENANCE

The battery must be kept clean and dry. Keep the terminals and poles clean. Every 10 hours, remove the caps and check the electrolyte level. If necessary top up with distilled water.

The battery should be serviced in a properly ventilated area. During this operation, do not expose the battery to naked flames and do not smoke. The battery has a 3 hours working life; if you notice that it is much shorter, check that:

- * the brushes are not obstructed;
- * the battery is completely charged.

5.2.1 - BATTERY RECHARGE



When the machine is off:

- remove the caps from their battery cells.
- Top up with distilled water.

NOTE

- Plug in a battery charger **pos. 3 Fig 3** bearing up to 12V 10A.

The life of the battery will depend on its routine maintenance and on its discharge level. Do not allow the battery charge to drop below the limit signalled by indicator lights **pos. 4 Fig. 3**. Got to the max. discharge level, the machine stops and need to be re-charge in order to restart working.

Charge indicator lights

Green light: The battery is charged.

Yellow light: The battery is running out; recharge as soon as possible.

Red light: The battery has run out. **DO NOT** operate the machine.

Every 200 hours of work, check the state of the motor carbon brushes and replacethem if they are worn.

Always try to replace them before they reach 1000 hours of work.

5.3 - FILTER MAINTENANCE

Cleaning the filter

The filter is one of the machine main components. It is essential for the best results from your machine. If you notice that dust forms when the machine is at work, check the filter.

The filter is cleaned as follows:

- A) Press and release the lever of the appropriate filter shaker **pos. 7 Fig. 3**. The lever operates a rod that will unclog the filter. Repeat this operation 5 or 6 times.

Electric filtershaker version (optional)

- A) By means of the button **pos. 10 Fig. 3** the electric filtershaker is activated. For the filter cleaning keep the button pressed for 5 seconds roughly. Repeat the operation 3 or 4 times.

- B) Apart from the filter shaker, it is advisable every now and again to remove the machine's filter and clean it out with a blast of air or a vacuum cleaner. For this purpose, the filter is removed as follows:

- remove the rear bin.

- Remove the filter stopping device **pos. 1 Fig. 6**.

- Remove the filter **pos. 3 Fig. 6** while holding up the filter shaker rod.

- To remount the filter **pos. 3 Fig. 6**, carry out the operation in reverse order.

ATTENTION: the filter features an arrow that shows you the direction in which it should be fitted.

Dusty environments

If you are using the machine in a particularly dusty environment (cement factories, sawmills, marble processing factories), it is wise to use the filter shaker more frequently.

Replacing the filter

Every 200 hours of work, the filter must be replaced. Follow the operations listed in point B).

After the filter has been remounted, make sure the gasket and filter are dust tight.

WASTES MUST BE DISPOSED OF IN ACCORDANCE TO THE LAW.

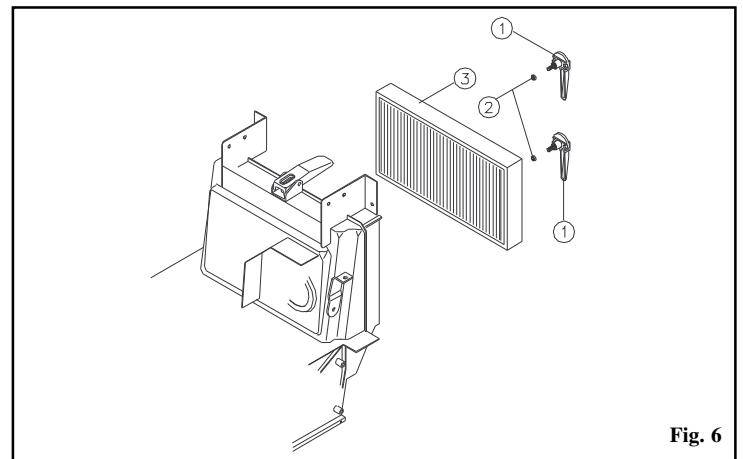

Fig. 6

5.4 - REPLACING AND ADJUSTING THE SIDE BRUSH

Replacing

After lifting the front part of the machine, replace the side brush by slackening the brush fixing screw **Fig. 2/A**, and removing the brush. Replace the brush and secure the new one in place with the screw and its washer.

Adjusting

The side brush is adjusted by slackening screws **pos. 1 Fig. 6/A** and using the slots to position the brush at the required height. Once you have positioned it, tighten the two screws.

5.5 - REPLACING THE ADJUSTING THE MAIN BRUSH

Replacing

To replace the main brush, remove the front bin and slacken the four fixing screws to remove the brush.

When mounting a new brush, pay attention to the direction in which the brush will spin: it must direct dirt toward the centre of the machine.

Adjusting versions 510ST - 710ET - 710ST (Fig. 6/A)

To adjust the main brush, remove the top bonnet, slacken the lock nut **pos. 3 Fig. 6/A** and turn adjusting handle **pos. 2 Fig. 6/B** in the direction required (clockwise to increase pressure). By pulling up the handle, the brush will turn idle. This will allow you to position the brush in a place where it will not prevent the top bonnet from closing.

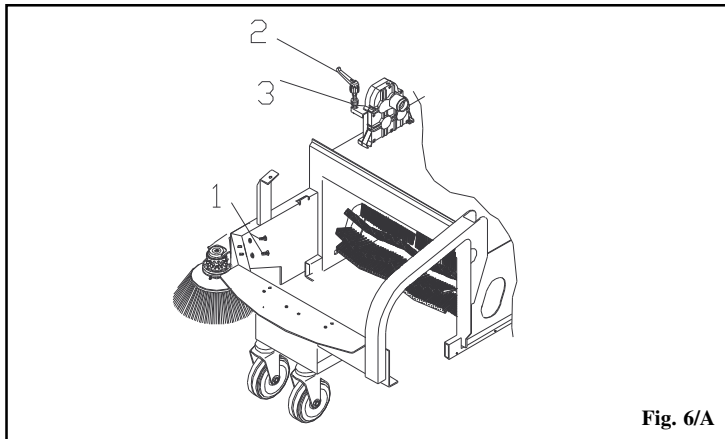

Fig. 6/A

Adjusting versions 510ET-711ET (Fig. 6/B)

To adjust the main brush, remove the top bonnet, slacken the lock nut **pos. 4 Fig. 6/B** and turn adjusting handle **pos. 5 Fig. 6/B** in the direction required (counterclockwise to increase pressure). By pulling up the handle, the brush will turn idle. This will allow you to position the brush in a place where it will not prevent the top bonnet from closing.

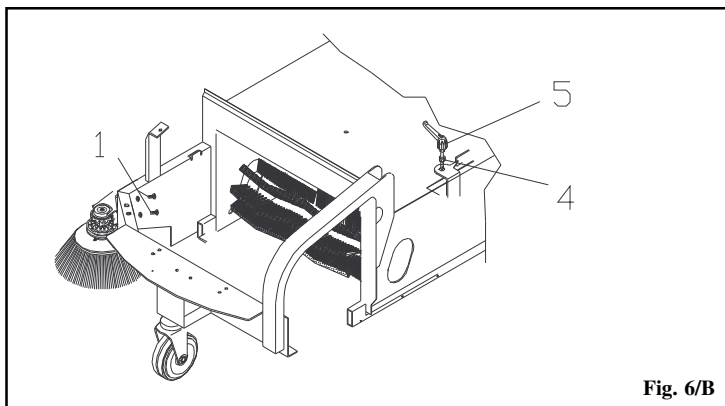

Fig. 6/B

5.6 - REPLACING AND ADJUSTING THE BELTS

To prepare the machine for belt replacement, carry out the following operations:

- remove the top bonnet and the front bin.
 - After removing the right wheel, loosen the screws that secure the bumper and right side guard in place and remove the latter.
- With the machine dismantled in such a manner, you can replace the damaged belt.

5.6.1 - Replacing the main brush belt

- Remove belt **pos. 7 Fig. 7** from the groove of pulley **pos. 6 Fig. 7**.
- Remove belt **pos. 5 Fig. 7** from the groove of pulleys **pos. 4 Fig. 7** and **pos. 6 Fig. 7**.
- Replace the belt.
- Position belt **pos. 7 Fig. 7** on pulley **pos. 6 Fig. 7**.

5.6.2 - Replacing the side brush belt

- Remove belt **pos. 7 Fig. 7** from pulley **pos. 6 Fig. 7**.
- Loosen fixing pin **pos. 8 Fig. 7** and let the hooks of side arm **pos. 9 Fig. 7** come out of the idle toothed ring.
- Remove belt **pos. 7 Fig. 7** from side arm **pos. 9 Fig. 7**.
- Replace the belt.
- Hook side arm **pos. 9 Fig. 7** to the idle toothed ring.
- Tighten pin **pos. 8 Fig. 7**.
- Place belt **pos. 7 Fig. 7** on pulley **pos. 6 Fig. 7**.

5.6.3 - Replacing the drive belt

- Loosen the pulley **pos. 4 Fig. 7** fixing screw and take it out of the reduction unit shaft, paying attention not to loose the key.
- Unscrew the pulley **pos. 3 Fig. 7** fixing screw and take it out of the reduction unit shaft, paying attention not to loose the key.
- Remove belt **pos. 1 Fig. 7**.
- Place the new belt on pulley **pos. 2 Fig. 7**.
- Mount pulley **pos. 3 Fig. 7** on the reduction unit along with the belt.

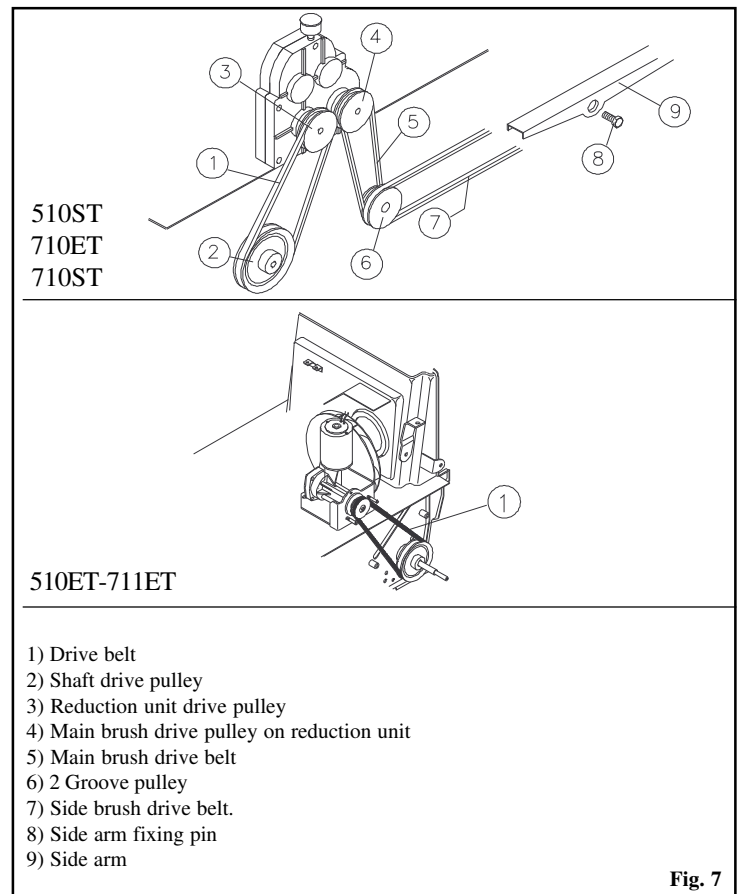

510ST
710ET
710ST

510ET-711ET

- 1) Drive belt
- 2) Shaft drive pulley
- 3) Reduction unit drive pulley
- 4) Main brush drive pulley on reduction unit
- 5) Main brush drive belt
- 6) Groove pulley
- 7) Side brush drive belt.
- 8) Side arm fixing pin
- 9) Side arm

Fig. 7

5.7 - REPLACING THE FLAPS

5.7.1 - Outer side flaps

To replace the side flaps **pos. 1 Fig. 8**, remove the rear wheels and the relevant side guards. Loosen the screws that secure the flaps to frame **pos. 2 Fig. 8** and replace the old flaps with new ones.

5.7.2 - Inner side flaps

To replace the inner side flaps **pos. 5 Fig. 8**, lift the front part of the machine and loosen screws **pos. 6 Fig. 8** that secure the flaps to the frame. Replace the old flaps with new ones.

5.7.3 - Centre flaps

- Remove the rear wheels and the relevant side guards.
- Remove the rear door.
- Loosen the two flap fixing pins **pos. 3 Fig. 8**, located on the sides of the frame.
- Grasp flap **pos. 4 Fig. 8** and pull it outwards.

Remounting:

- Fit the flaps in the same direction in which they are removed.
- Insert the two references in their holes.
- Tighten the two fixing pins and reassemble the machine.

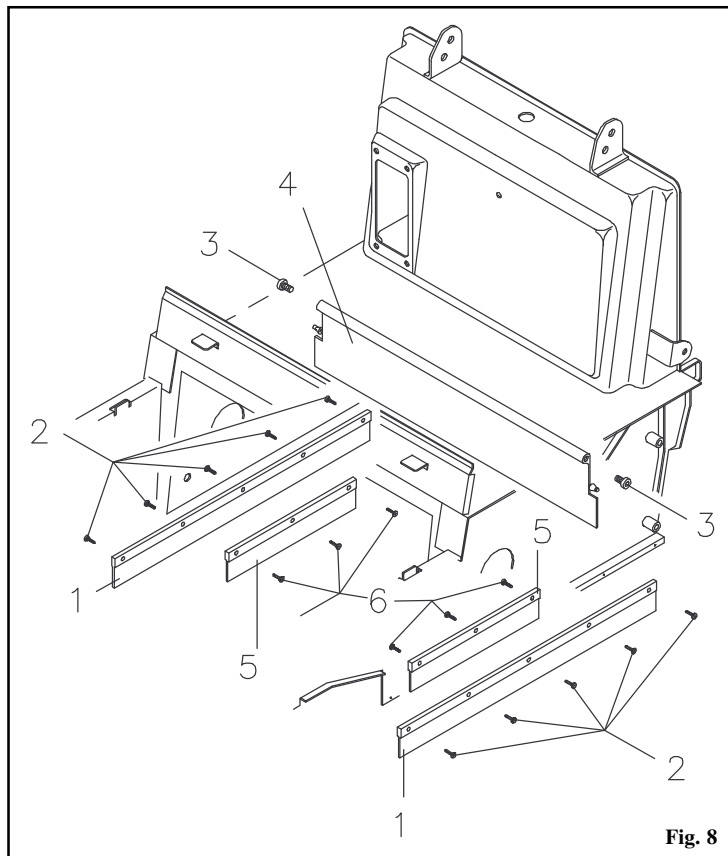

Fig. 8

5.8 - REPLACING THE TRACTION CABLE

5.8.1 - Remove the traction cable as follows

To replace the traction cable proceed as follows:

- Remove the upper bonnet of the machine.
- Loosen the security dowel located on the cable fixing pin.
- Pull the cable out of the fixing pin and remove the adjusting screw mounted on the handle.
- Press the handle and pull the cable out of its sheath.

To remount the cable:

- Fit one end of the cable into the adjustment screw of the handle (i.e. the end without the blocking ball).

- Insert the cable into its sheath.
- Hook the blocking ball to the handle.
- Slot the cable through the turned adjustment screw secured to the machine frame and then through the fixing pin.
- Tighten the security dowel.

The position of the cable is adjusted by acting on the two adjustment screws.

5.8.2 - Replacing the side brush lifting cable

To replace the side brush lifting cable, proceed as follows:

- Remove the upper bonnet and the front bin of the machine.
- Remove the front bumper, the right wheel and the right hand side guard.
- Loosen the cable clamp.
- Loosen the security dowel on the fixing pin.
- Remove the handle from the support and open it up.
- Pull the cable out of the two sheaths.

To remount the cable:

- Put the cable inside the handle.
- Close the handle and fix it to its support.
- Insert the cables into their sheaths.
- Secure one end of the cables in place with the clamp and the other end with the fixing pin.

The position of the cable is adjusted by acting on the two adjustment screws.

5.9 - REPLACING MOTOR FAN (Electrical version)

To replace the motor fan proceed as follows:

- Remove the top bonnet.
- Disconnect the battery cables and take the battery out of the machine.
- Disconnect the power supply coders of the motor from the plug.
- Remove the stop for the cable holder from the motor.
- Loosen the four motor fixing screws.
- Replace the motor by carrying out the above operations in reverse order.

Make sure the motor is mounted level with the fan.

IMPORTANT: WHEN CONNECTING THE MOTOR RESPECT THE POLARITY.

